

SCT8162X

If you have any questions please contact
wesley-lin@silicontent.com
sales@silicontent.com

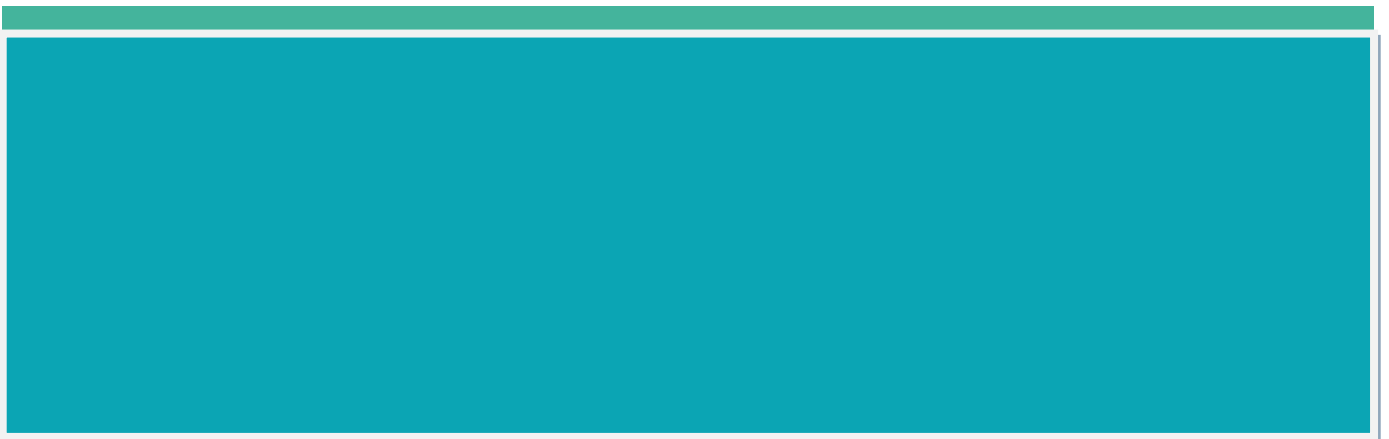

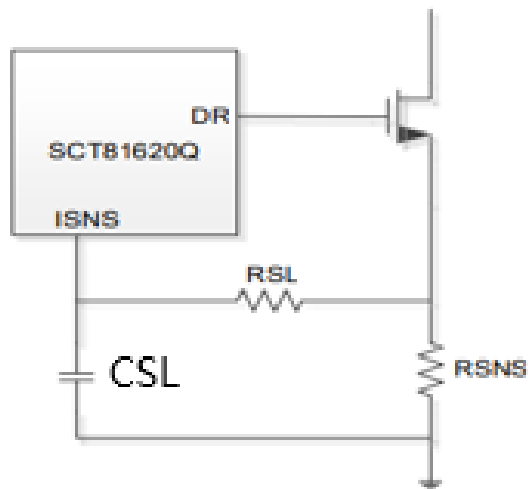

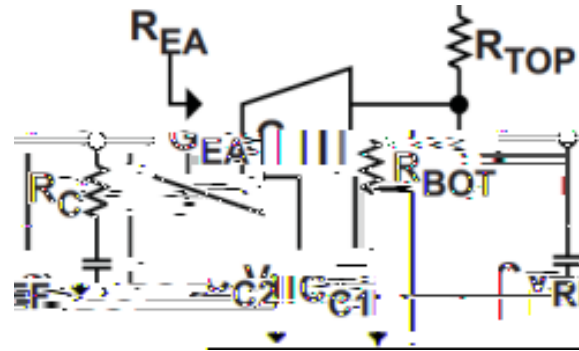

封装和脚数	产品	控制拓扑	最小输入电压(V)	最大输入电压(V)	静态电流(μA)	电流保护模式	开关频率(Hz)	抖频功能	封装
	SCT81620	升压, 反激, Sepic	3.2	50	450	Hiccup	100k-2.2M	√	MSOP-8
	SCT81621	升压, 反激, Sepic	3.1	50	415	Hiccup	100k-2.2M	√	MSOP-10
	SCT81624	升压, 反激, Sepic	3.1	50	415	恒流	100k-2.2M	-	MSOP-10
	SCT81620Q	升压, 反激, Sepic	3.2	50	450	Hiccup	100k-2.2M	√	MSOP-8
15	Hiccup	100k-2.2M	√	MSOP-10	SCT81621Q	升压, 反激, Sepic	3:1	50	4
15	恒流	100k-2.2M	-	MSOP-10	SCT81624Q	升压, 反激, Sepic	1:3	50	4