

---

**3V-40V Vin, 500mA, Ultra-Low Quiescent Current LDO with Power-Good**





---

---

---

---

--	--	--	--	--

	( )			
	( )			

	) (			
	) (			

---

---



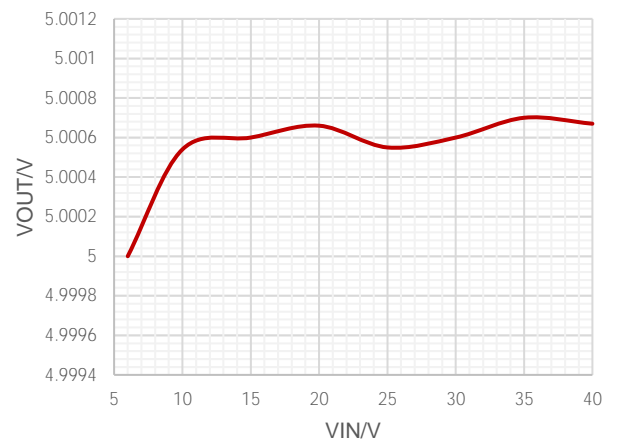
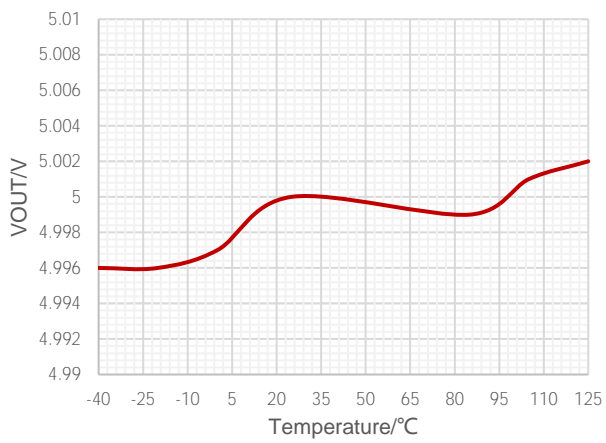
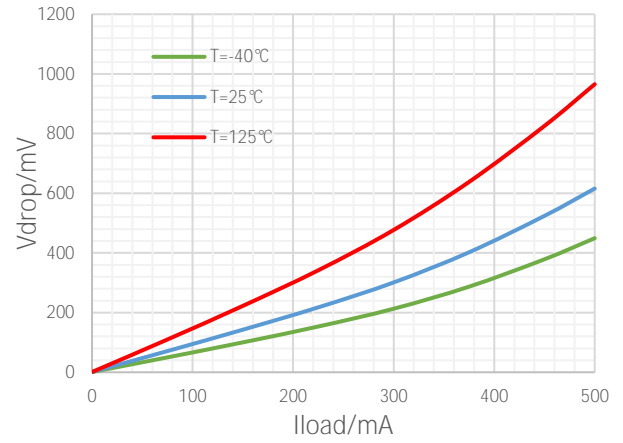
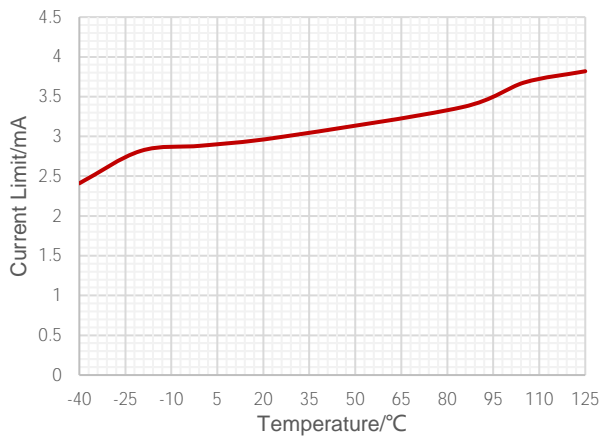
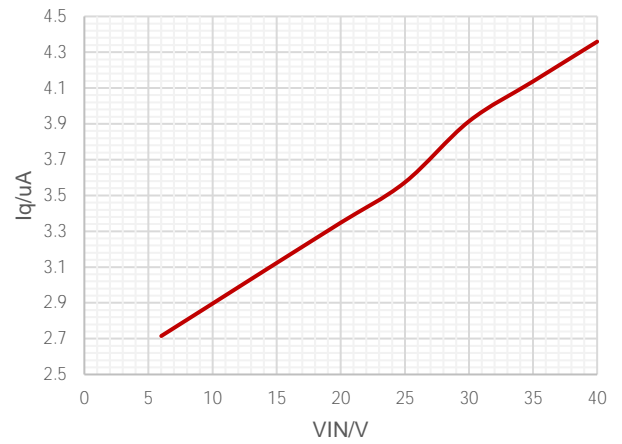
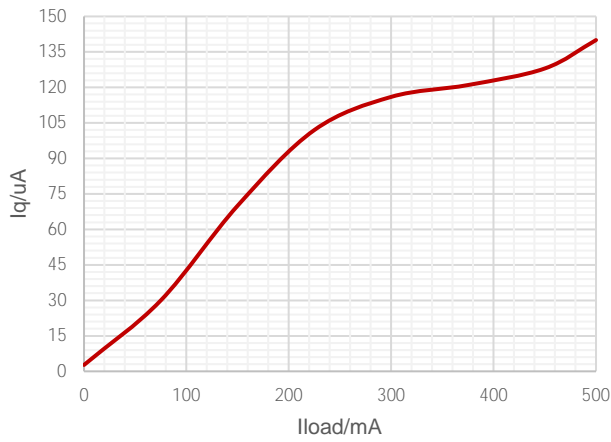

---

V<sub>OUTN</sub>

5.002

5

4.998

4.996

4.994

4.992

4.99

4.988

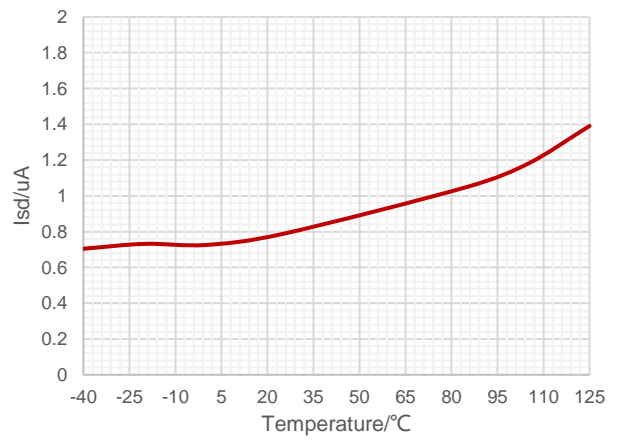

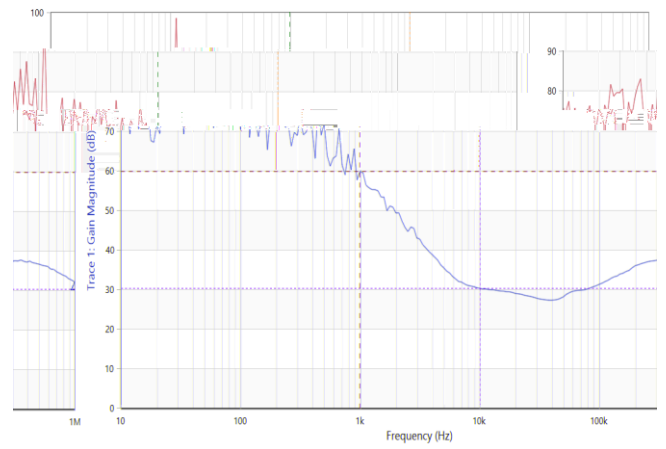
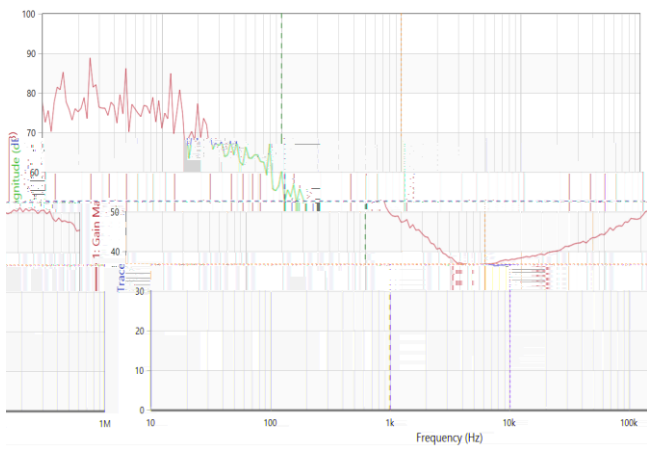
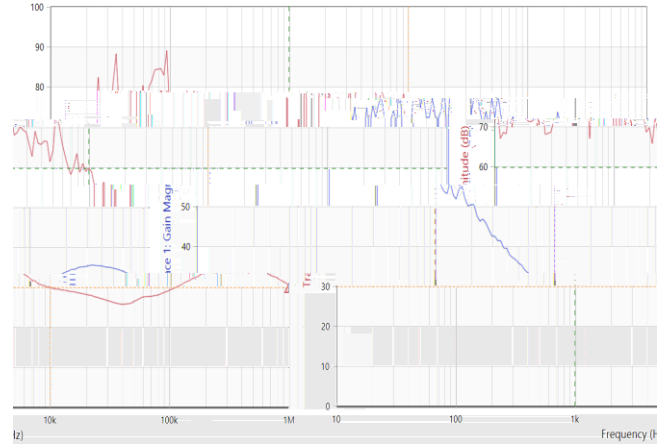
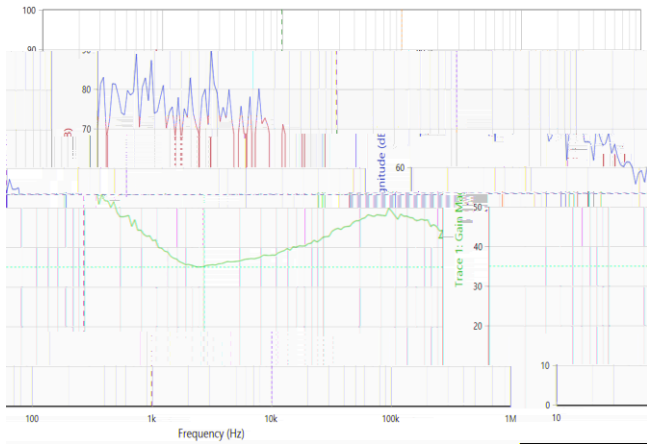
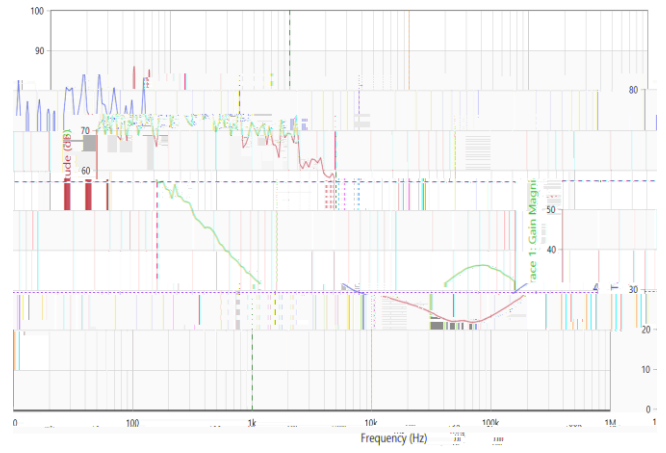
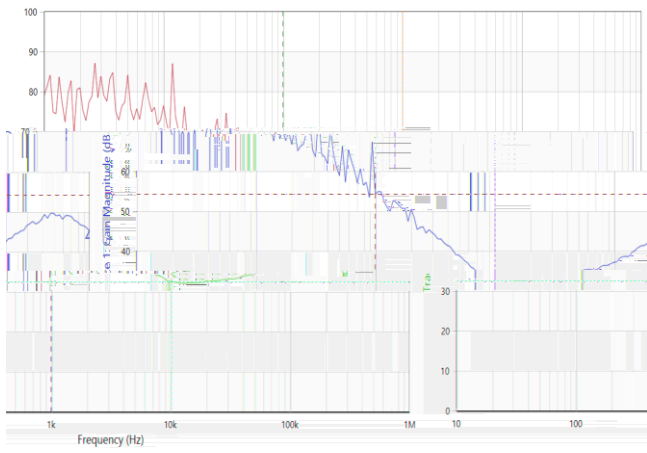

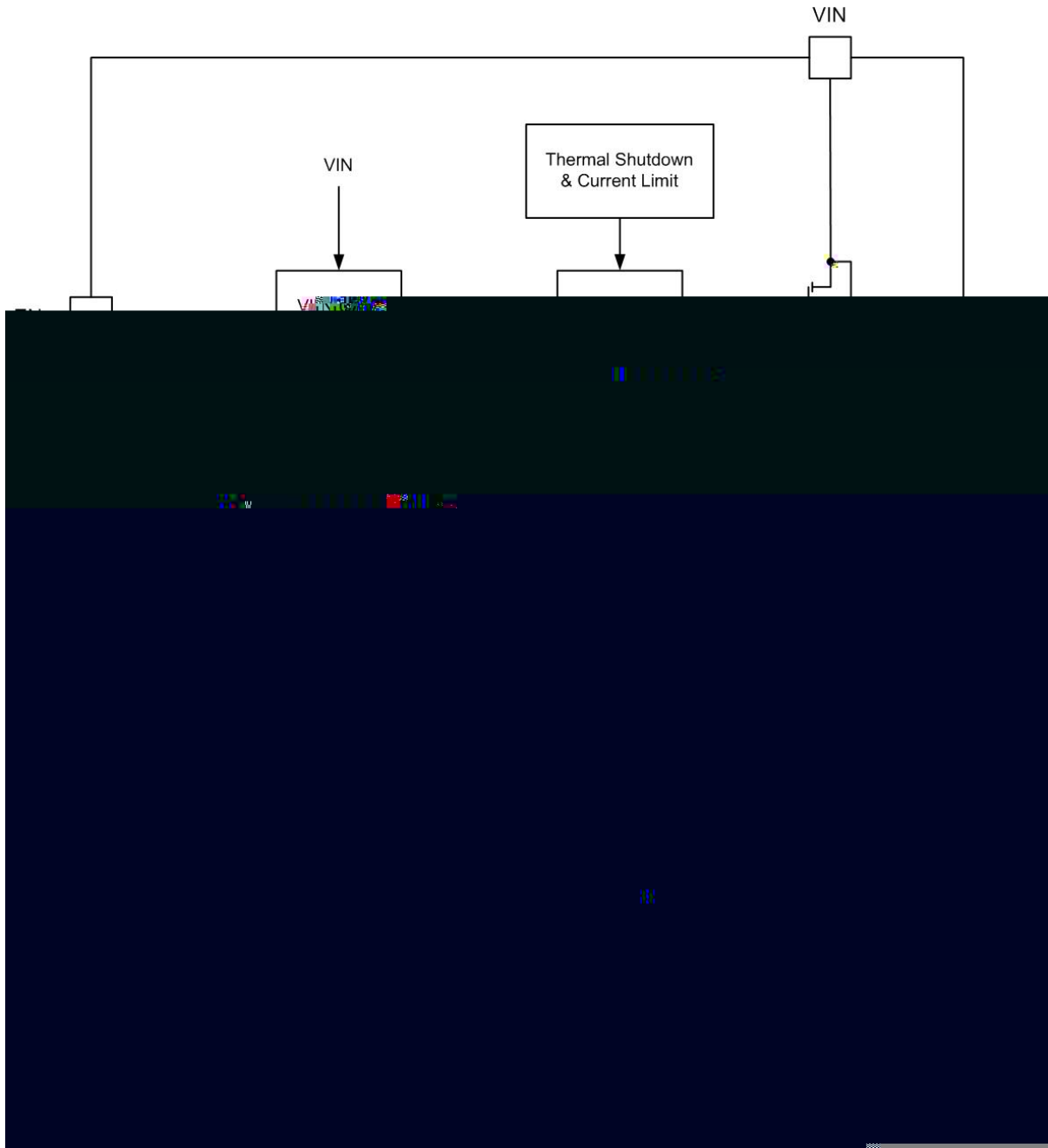



---

## VIN\_HIGH Control

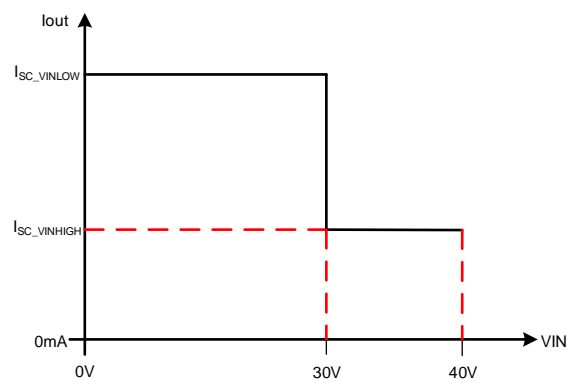

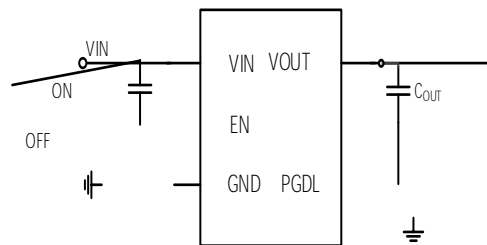
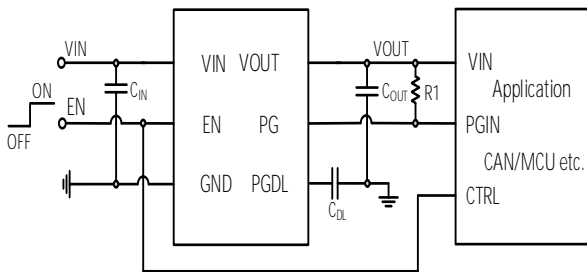
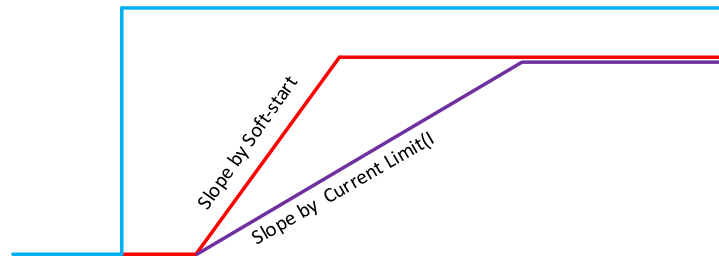





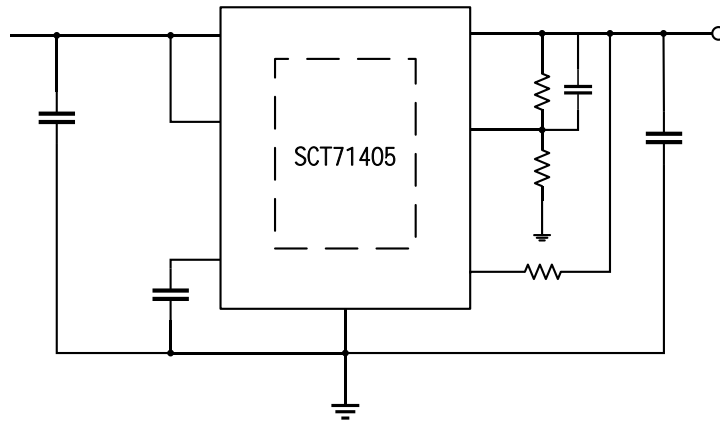

---

---

---

---

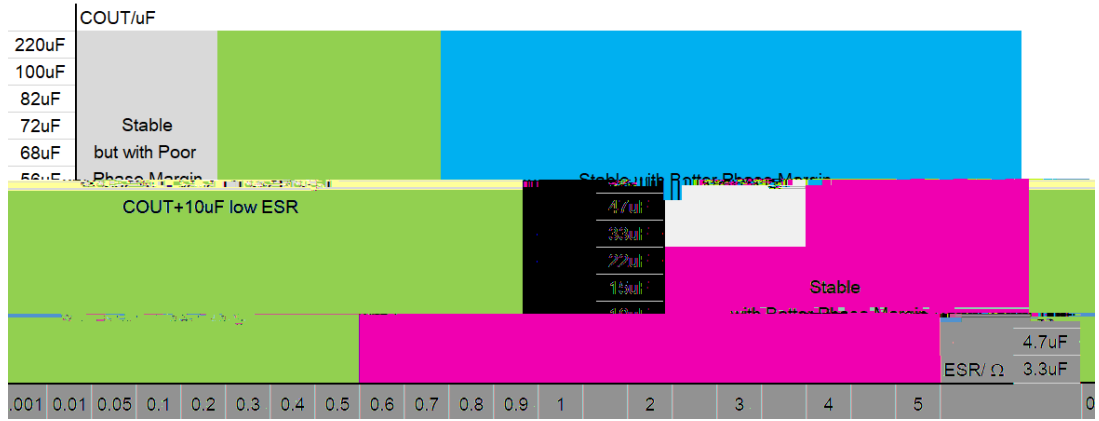



---

---

---

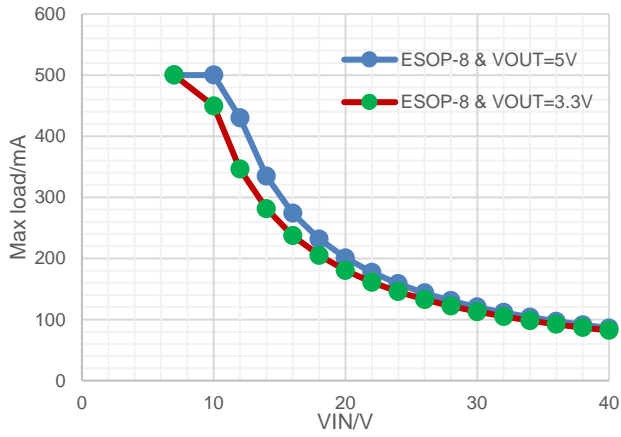
---



°C

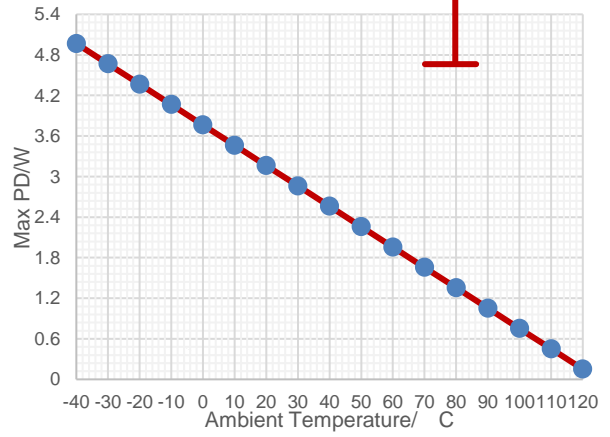

°C

°C

°C





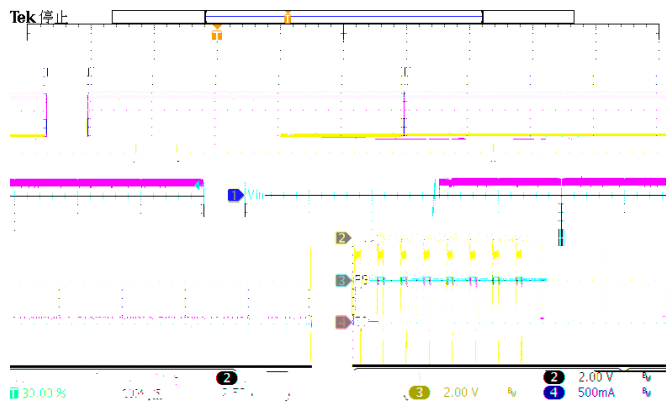
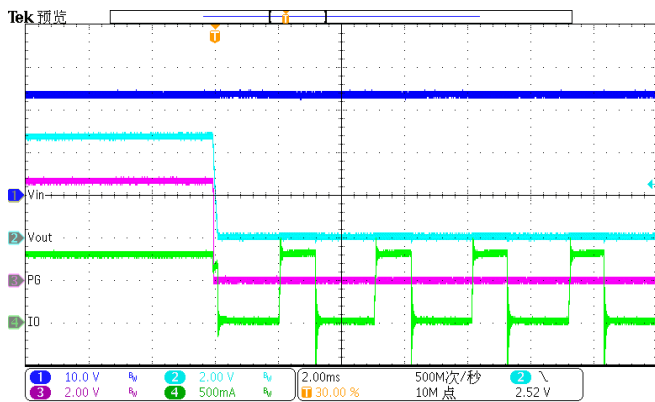
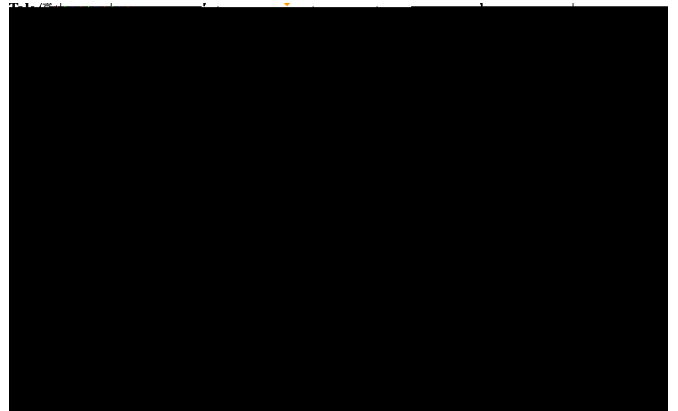
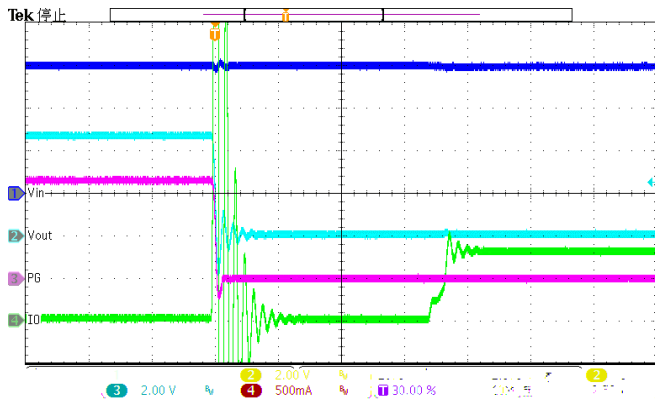
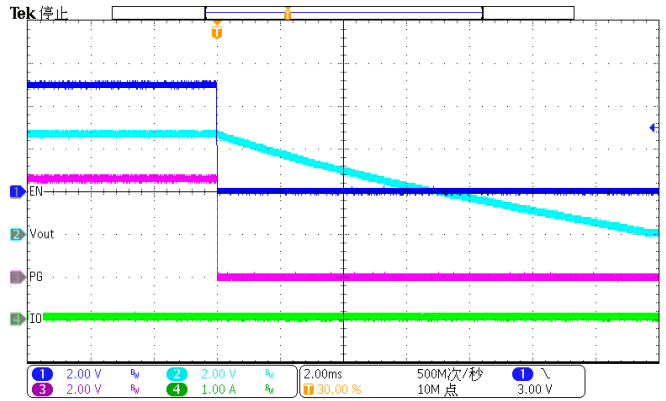
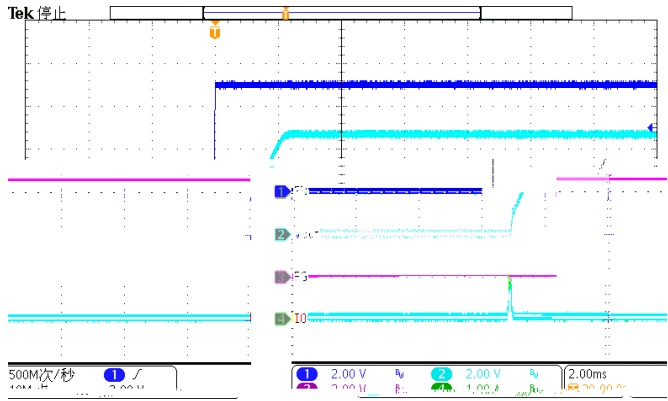

- 
- 1.
  - 2.
  - 3.

**PACKAGE OUTLINE OF WITH LEAD PITCH FOR USE**  
**FD-0022 revision 1.0**

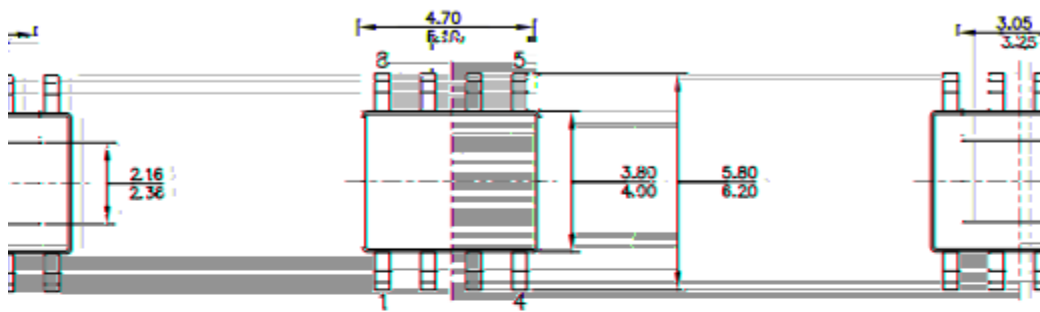

**VIEW** **TOP VIEW** **BOTTOM**

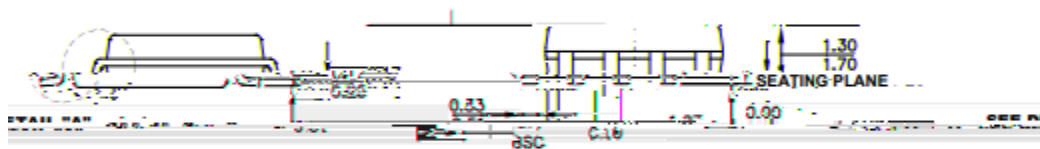

**VIEW** **FRONT VIEW** **SIDE V**

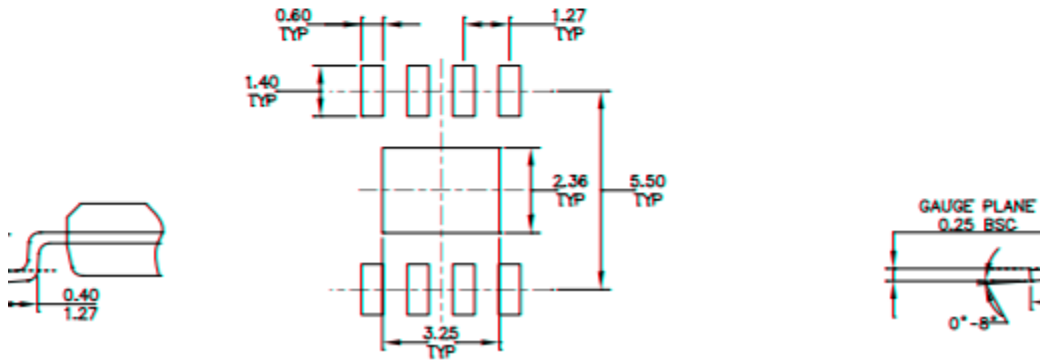

**L "A"** **RECOMMENDED LAND PATTERN** **DETAIL**

- 1.
- 2.
- 3.
- 4.
- 5.
- 6.

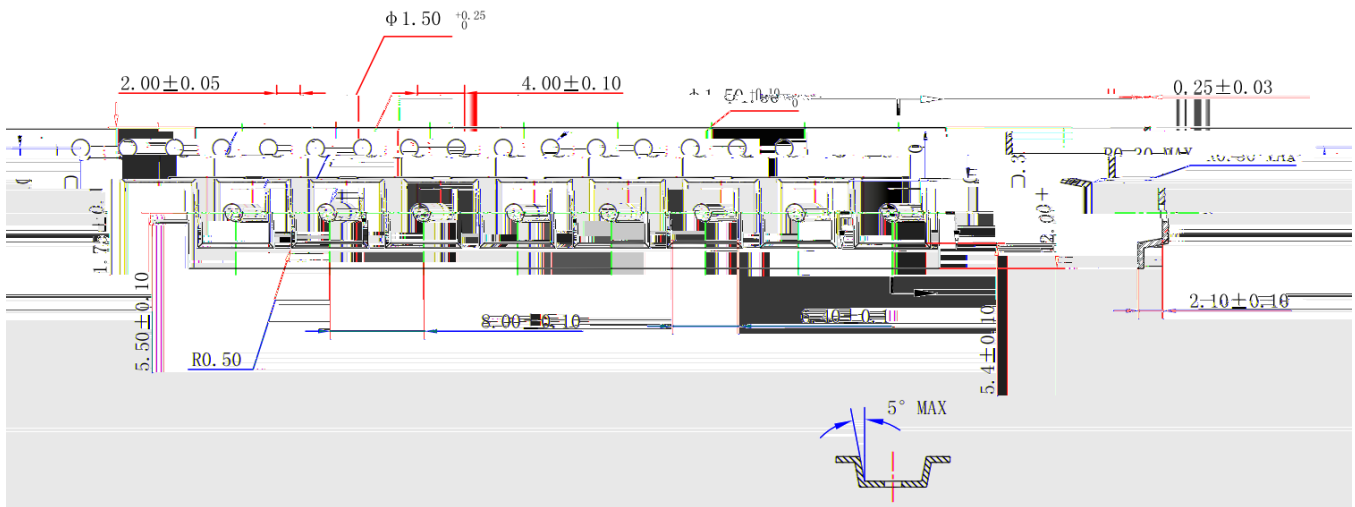
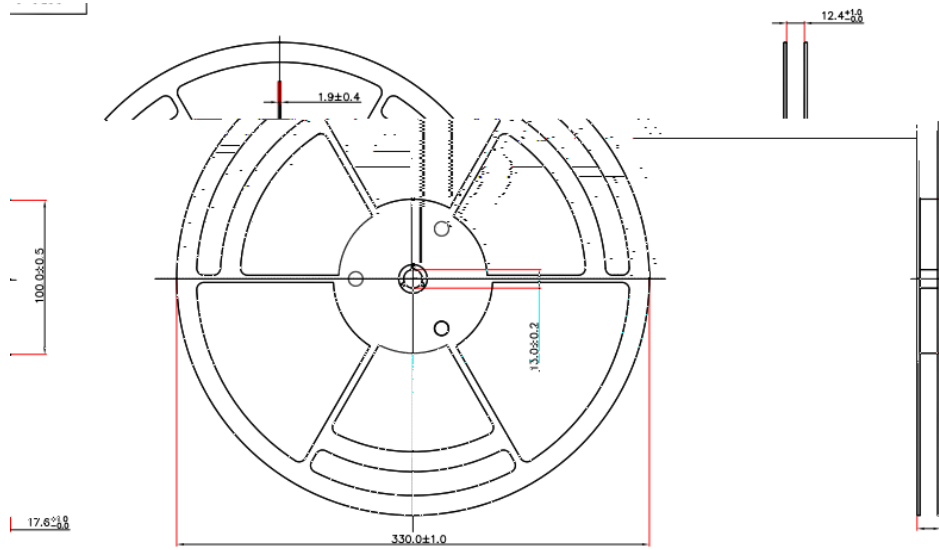

**NOTICE:** The information in this document is subject to change without notice. Users should warrant and guarantee the third party Intellectual Property rights are not infringed upon when integrating Silicon Content Technology (SCT) products into any application. SCT will not assume any legal responsibility for any said applications.

---

**NOTICE:** The information in this document is subject to change without notice. Users should warrant and guarantee the third party Intellectual Property rights are not infringed upon when integrating Silicon Content Technology (SCT) products into any application. SCT will not assume any legal responsibility for any said applications.

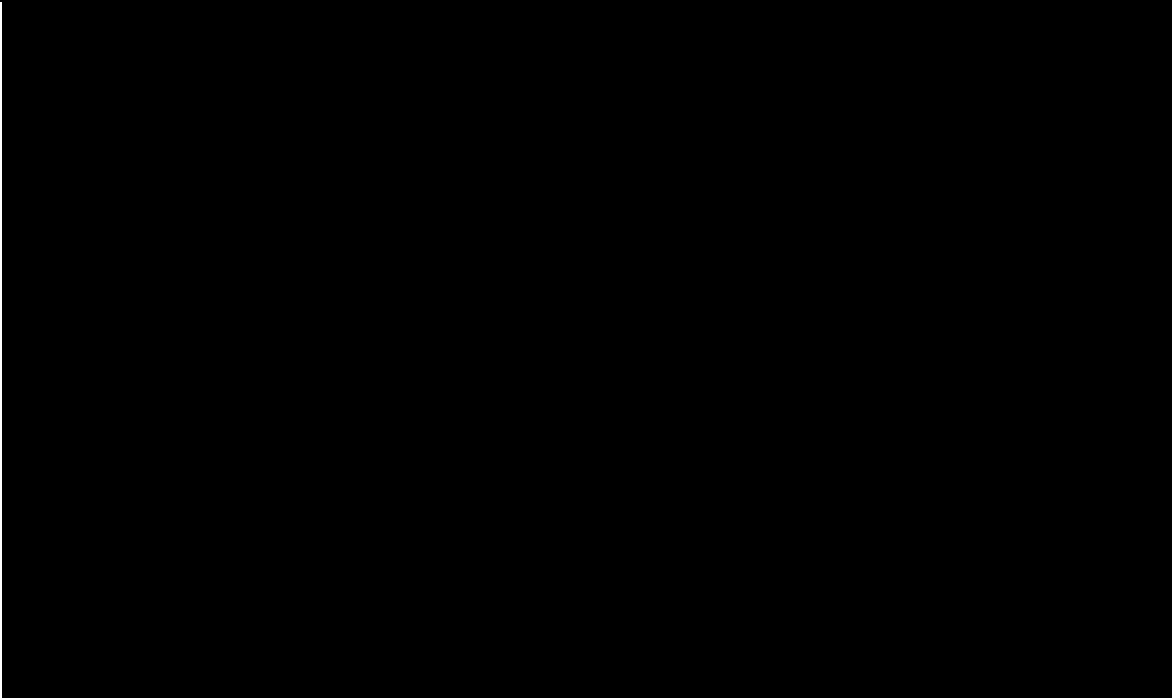
---

---