

## 4.5V-60V Vin, 0.6A, High Efficiency Step-down DCDC Converter

### FEATURES

- 
- 
- 
- 
- 
- 
- 
- 
- 
- 
- 
- 

### DESCRIPTION

- 
- 
- 

### APPLICATIONS

- 
- 
- 
- 
-

---

## REVISION HISTORY

## DEVICE ORDER INFORMATION

1)		

## ABSOLUTE MAXIMUM RATINGS

--	--	--	--

## PIN CONFIGURATION

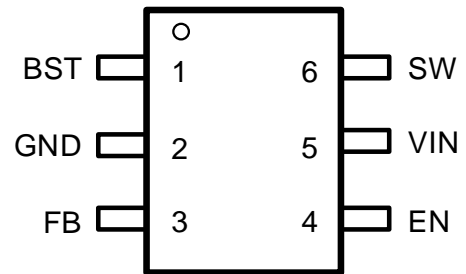

---

## RECOMMENDED OPERATING CONDITIONS

## ESD RATINGS



(1)



---

## TYPICAL CHARACTERISTICS

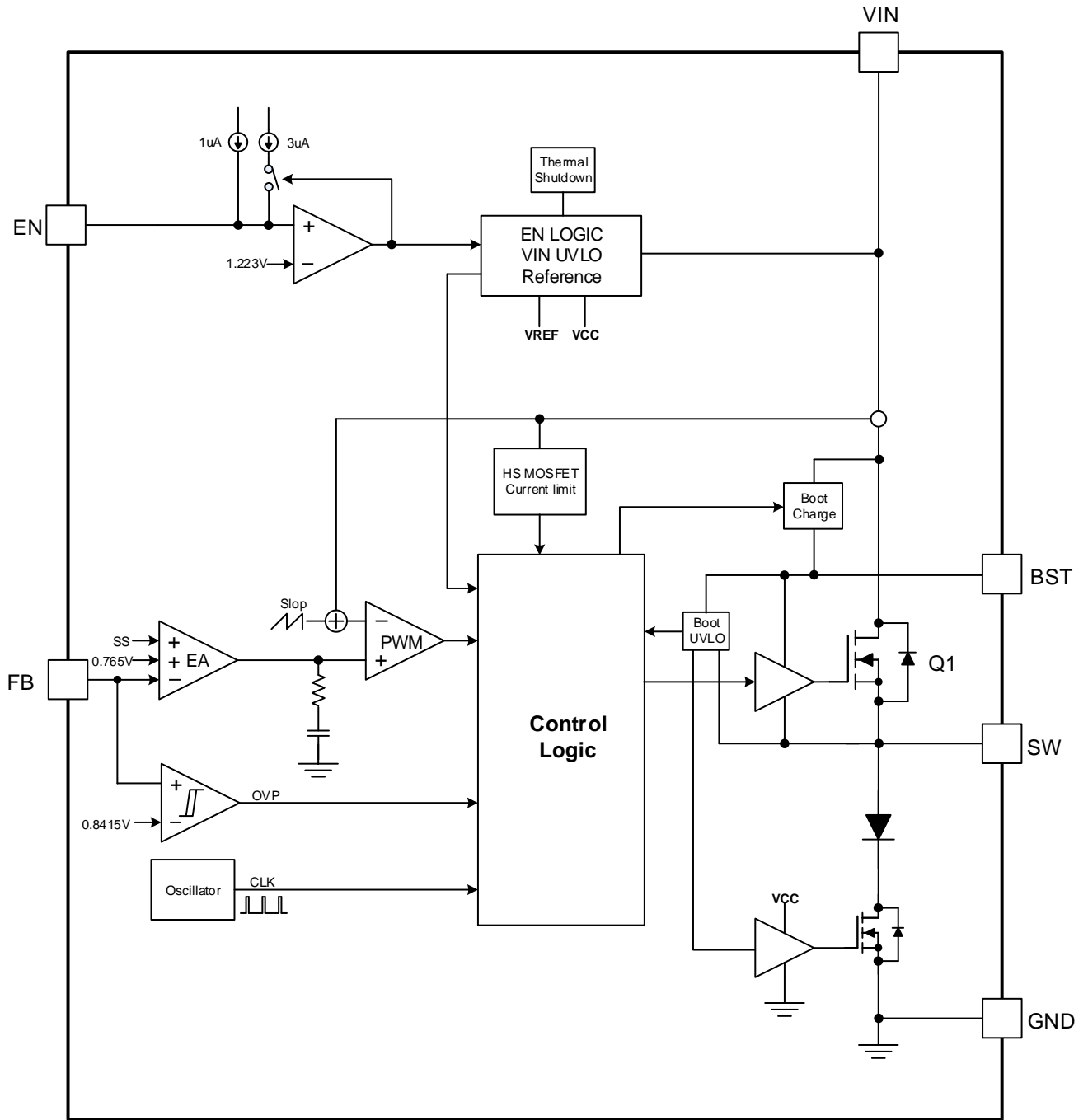
# FUNCTIONAL BLOCK DIAGRAM



---

**OPERATION**

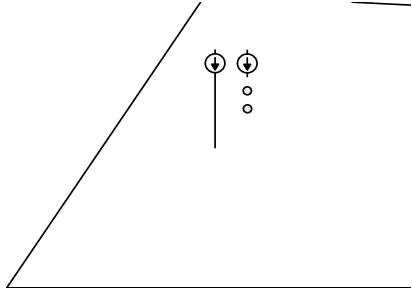

- 
- 

±2.5



- 
- 





---

---

---

---









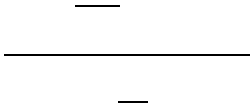

- 
- 
- 
- 
- 
- 



- 
- 
- 
- 



---

- 
- •  
•  
•  
•  
•

---



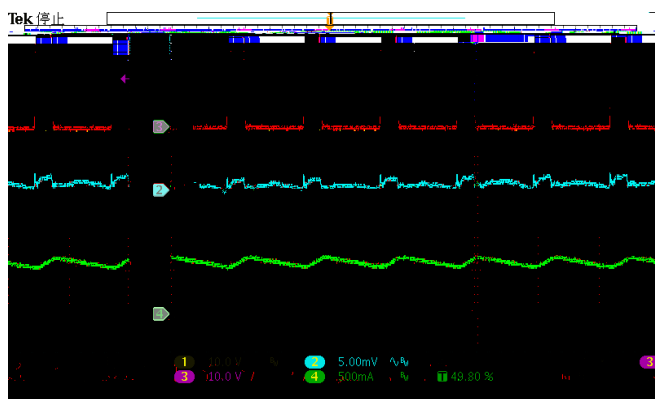
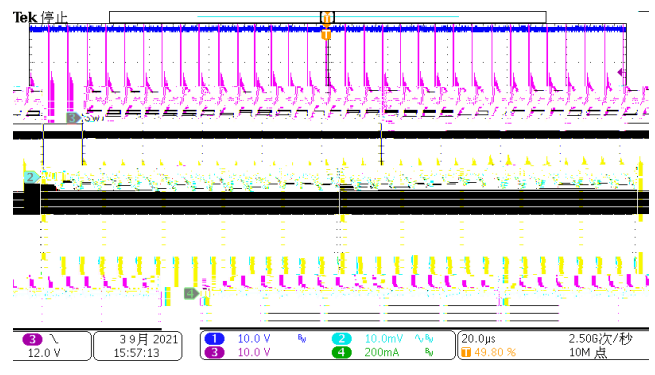
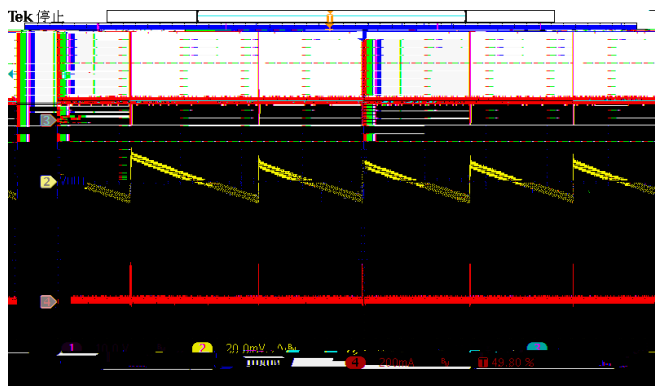
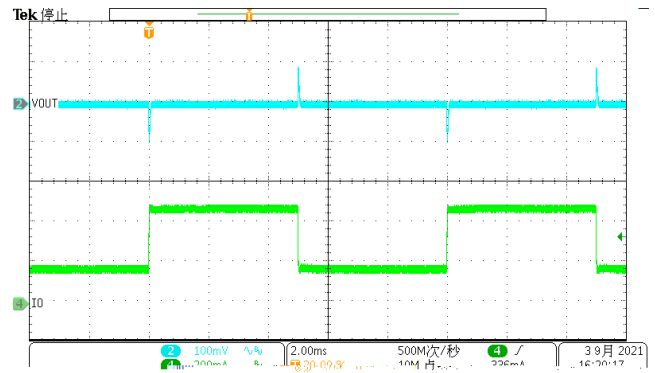
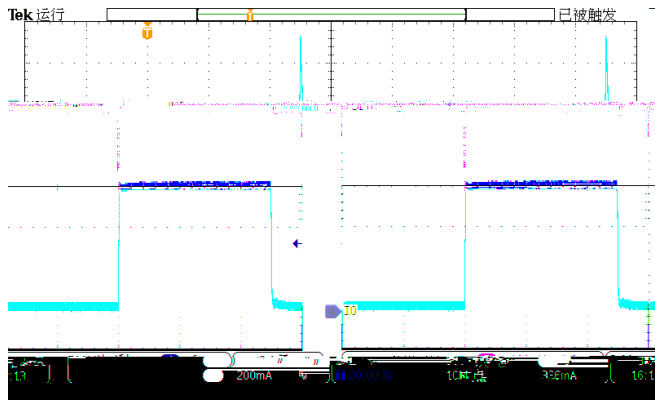

- 1.
- 2.
- 3.
- 4.
- 5.
- 6.

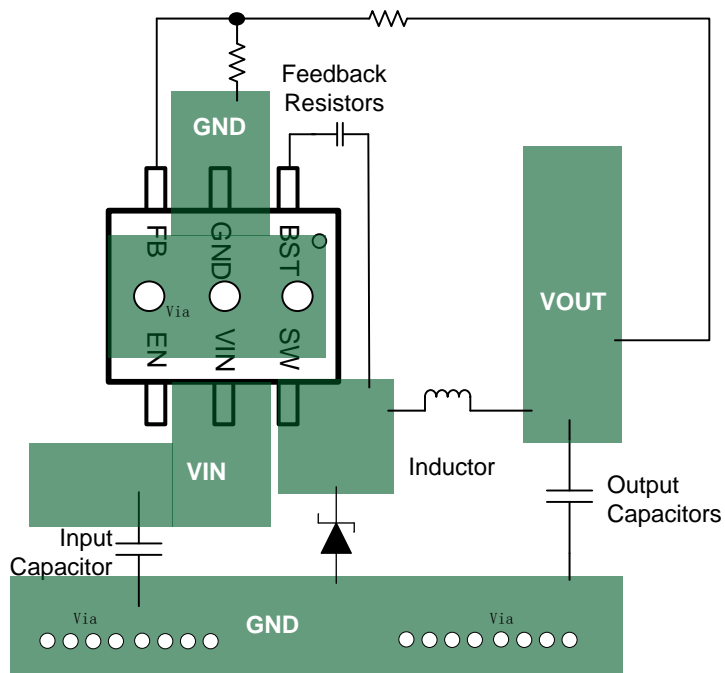

•  
•



---

## TAPE AND REEL INFORMATION